

## ▶ Hall sensor- and contact monitor (8 channel, parallel interface)

E910.41

### FEATURES

- ▶ Supply voltage range VS 5.25 to 25V
- ▶ Supply voltage range VDD 4.75 to 5.25V
- ▶ Maximum overvoltage protection up to 40V
- ▶ Low standby current (typical IS = 13µA)
- ▶ Contact status monitoring by comparison of the switch resistance with internal reference
- ▶ Inputs are current limited
- ▶ High noise immunity
- ▶ Overtemperature protected
- ▶ -40°C to +125°C operating temperature
- ▶ SO20w package

### APPLICATION

- ▶ Automotive electronics
- ▶ Monitor for Hall Sensors
- ▶ Monitor for mechanical switches

### DESCRIPTION

The IC is developed for automotive applications. It continuously monitors up to 8 hall sensors or switches to GND.

The input currents are compared to internal references. Currents exceeding -11mA will force a logic '0' at the output, while currents higher than -6mA will result in a logic '1' at the output.

If the IC is used to monitor switches, the switch resistance must be higher than 5kΩ for '1' and less than 330Ω for '0' at the output.

The input current as well as the tristate driver are activated with the enable pin. Due to the tristate outputs the IC can be used in bus configuration.

### PINNING

Pin	Name	Description
1	VS	Supply voltage
2	IN0	Input for sensor or switch to GND
3	IN1	Input for sensor or switch to GND
4	IN2	Input for sensor or switch to GND
5	IN3	Input for sensor or switch to GND
6	IN4	Input for sensor or switch to GND
7	IN5	Input for sensor or switch to GND
8	IN6	Input for sensor or switch to GND
9	IN7	Input for sensor or switch to GND
10	EN	Chip enable for input current and tristate outputs, active low
11	GND	Ground
12	OUT7	TTL compatible tristate data port
13	OUT6	TTL compatible tristate data port
14	OUT5	TTL compatible tristate data port
15	OUT4	TTL compatible tristate data port
16	OUT3	TTL compatible tristate data port
17	OUT2	TTL compatible tristate data port
18	OUT1	TTL compatible tristate data port
19	OUT0	TTL compatible tristate data port
20	VDD	Logic supply voltage

### PACKAGE

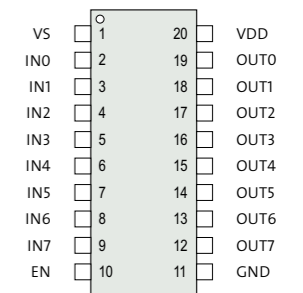

### BLOCK DIAGRAM

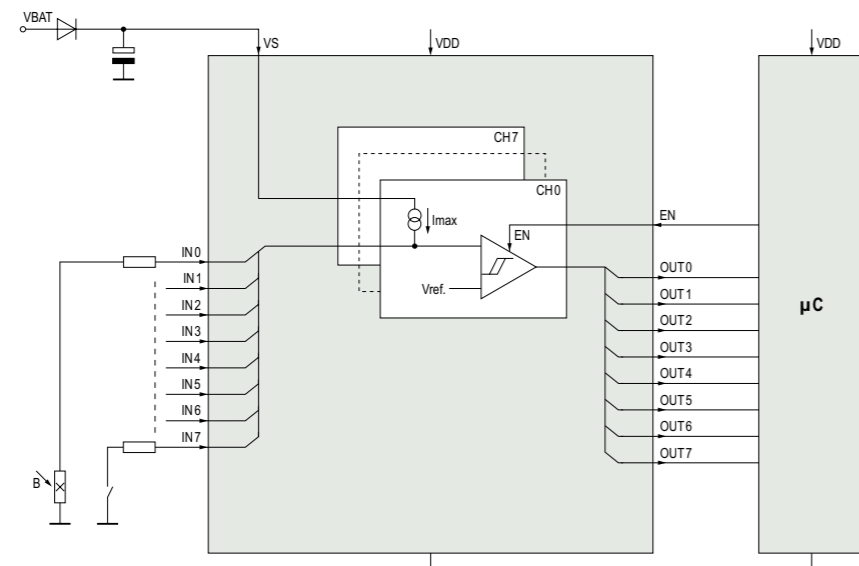

*Note* ELMOS Semiconductor AG (below ELMOS) reserves the right to make changes to the product contained in this publication without notice. ELMOS assumes no responsibility for the use of any circuits described herein, conveys no licence under any patent or other right, and makes no representation that the circuits are free of patent infringement. While the information in this publication has been checked, no responsibility, however, is assumed for inaccuracies. ELMOS does not recommend the use of any of its products in life support applications where the failure or malfunction of the product can reasonably be expected to cause failure of a life-support system or to significantly affect its safety or effectiveness. Products are not authorized for use in such applications.

Copyright © 2005 ELMOS Reproduction, in part or whole, without the prior written consent of ELMOS, is prohibited.

www.elmos.de | sales@elmos.de